

Electrical Actuator with reinforced torque reduction for butterfly valve control, designed for valves using ISO 5211 top flange

**MS-35M
incl MTS-70**

mi-279gb / 2009-03-12



Application

Actuator MS-35M with reduction kit MTS-70 is designed for the control of butterfly valves in warm water pipes. Using the reduction kit MTS-70 allows mounting of the actuator on many different brands of valves that correspond to the ISO 5200 top flange and in pipe dimension between DN 50 to 200 mm depending on the rotation torque of the valve. Most suitable on soft-seated valves with EPDM rubber sealing. Micatrone also delivers complete valves with mounted actuator in series MTT.

Design

The actuator has a high degree protective enclosure and a solid construction for use in harsh environments such as boiler plants and other similar industrial applications. High nominal torque synchronous motor with 30 Nm, enhanced with a special developed reduction, MTS-70, increases the torque to 160 Nm when moving the valve in closed position. MTS-70 allow connection against valves using F05, F07, F10 top flange size. Ball-bearing supported transmission between the lever mounted on the valve and MTS-70 reduction kit.

The actuator can be mounted in any position. It is although recommended to place the actuator in such a way that eventual leakage from valves does not drip on the actuator to avoid short-circuiting the electrics. The actuator normally require no maintenance. The actuator is fitted with three limit switches as standard:

- 2 pcs for adjusting the end limit for open and closed valve
- 1 pc potential-free changing micro switch, adjustable 0...90 ° for use as output signal

Mounting the lever on the valve

If the valve not already is mounted in the pipe, it simplifies if the valve is mounted to a vice or other stand while mounting of lever and actuator on the valve. Following dimensions of lever for the valve are available as standard.

Valve shaft diameter in mm	Round shaft with 2 opposite levelled sides parallel to disc	Round shaft with 4 levelled sides 45° against disc.
12	YES	NO
16	YES	NO
18	NO	YES
20	YES	NO
22	NO	YES

Push the lever to the bottom of the valve shaft with bushing facing out-wards. Check that the lever is 90° in angle against the levelled sides on the shaft and to the disc of the valve according to figure (this is applicable for valves with two opposite levelled sides on the shaft, and parallel to the disc, i.e. Double-D type shaft).

Tighten the HEX screws on the lever bushing hard.

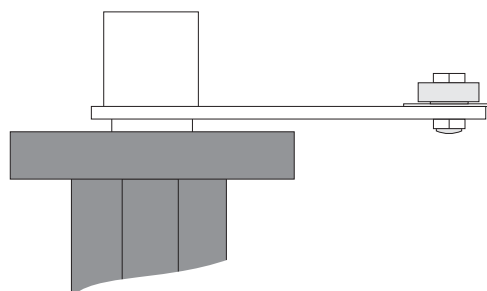
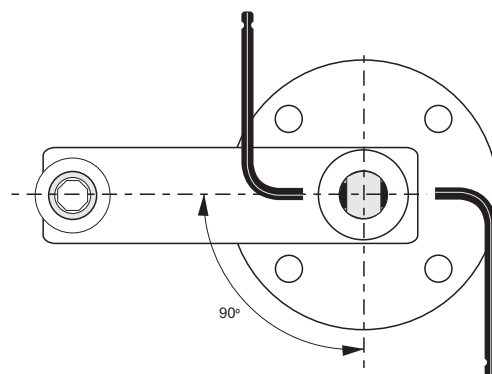

Mounting of actuator

MS-35M actuator for valves is delivered with pre-adjusted limit switches for open and closed position.

The actuator include pre-mounted reduction kit, MTS-70, with mounting plate and spacers for the ordered top flange.

The actuator is delivered with three nuts or bolts depending of dimension and type for fixing to the valve.

Place the actuator on to the valve according to figure, make sure that the ball-bearing on the valve lever is placed correctly in the slot. Mount the bolts or nuts and tighten all to fix the actuator to the valve.

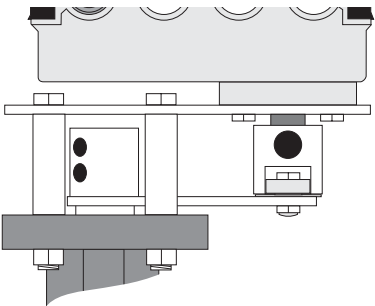
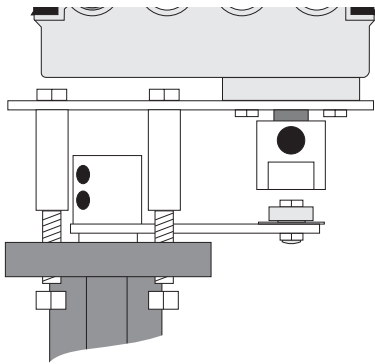

Remove the actuator cover and check the limit switches by pressing the release mechanism for the output shaft and turning the valve manually between the end positions. When each cam is affecting the limit switch, a weak "click" sound occur .

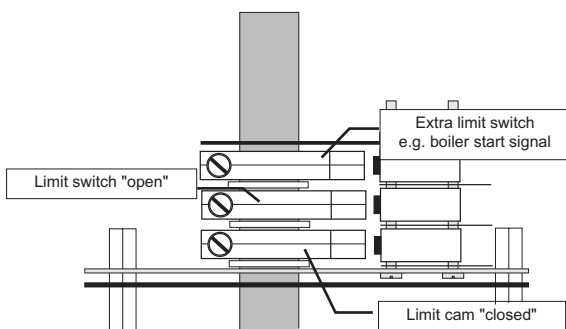

Check that the ball-bearing is moving in the slot without jamming when turning the valve between the end positions. The entire height of the ball-bearing should be inside the slot to ensure safe operation. If this is not the case, the lever of the valve can be loosen and moved on the valve centre shaft until the ball-bearing is in place. Never loosen the lever on the actuator since it tighten with a high and specific torque.

Note ! If lever and actuator is to be mounted on valve already installed in the water pipe that the actuator can be mounted in two directions, with or against the flow direction, select the direction most suitable to manoeuvre the valve and for electric installation of the actuator.

Before connecting the actuator electrically, make sure that the valve can be manoeuvred with the release mechanism between the open and closed position without jamming. Check at the time that the limit switches are correctly adjusted for both positions. It is important that the cams affect the limit switches before the valve stops against any mechanical end stop.

The third cam can be adjusted to affect the limit switch somewhat before an fully open valve to obtain start signal for burner.

The electrical connection can be found on a label inside the cover of the actuator.

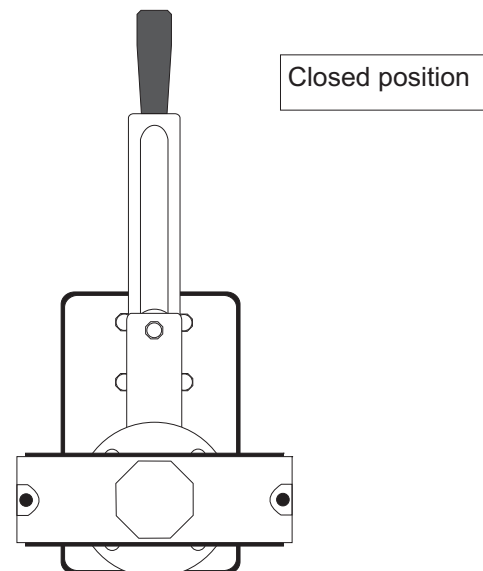
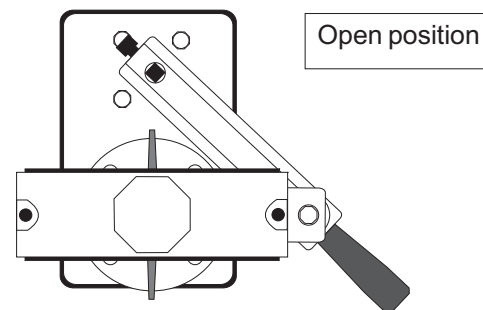

Technical data:

Duty ratio: Class I 100%
 Torque: Nom. 30 Nm, with MTS-70 max 160 Nm

Rotation speed:
 @ 50 Hz voltage cycle: 90° at 60 sec.
 @ 60 Hz voltage cycle: 90° at 50 sec.
 Rotation angle: Adjustable 0...90° of valve disc

Supply voltage: 230 VAC, +15, -10 %
 Power consumption: Max. 10 VA

Ambient temp: Standard -15...+55 °C
 Degree of protection: IP 54
 Cable entries: 3 x M20 x 1,5
 Electrical conn: 2 x 1,5 mm²/per terminal

Material:
 El-motor 1-phase, synchronous
 Gears Steel
 Output shaft Steel ø15mm 12x12mm
 Enclosure Black poly carbonate
 Weight: 3,9kg excl accessories
 Load limit switches: 250 VAC for 50 000 changes: 3 A
 250 VDC for 50 000 changes: 0.2 A

Accessories:

- Potentiometer kit MTS-50
- Heat resistor kit MTS-60
- Extra limit switch MTS-30/40

Complete valves with actuator:

- Soft-seated series MTT-F38 DN 50...200
- Metal-seated series MTT-HG DN 50...150



Example: MTT-80,
 Soft-seated butterfly valve DN -80
 with actuator MS-35M and MTS-70

Electrical connection standard MS-35M3:

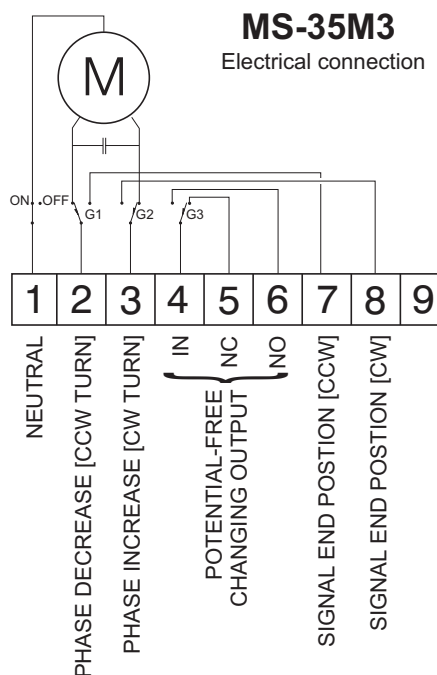

Dimensions without reduction kit MTS-70

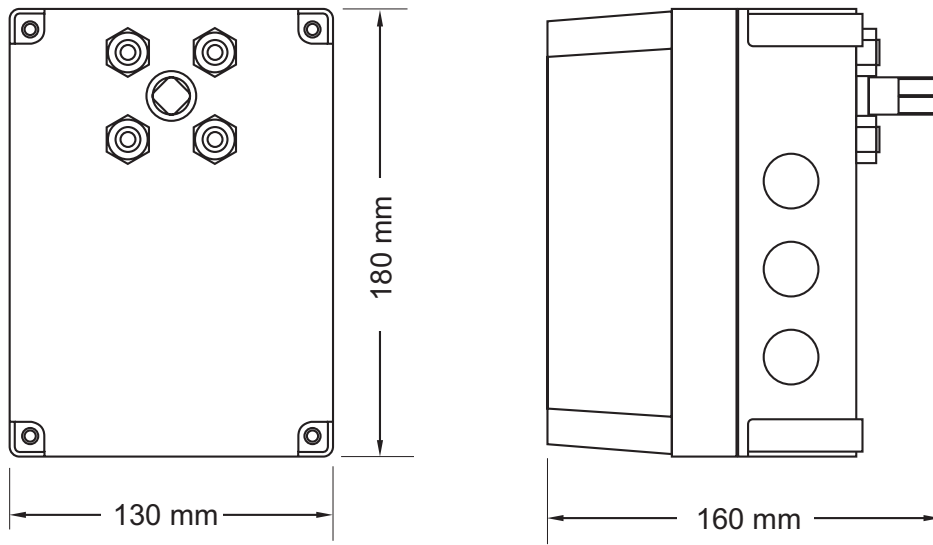

Required space to operate the valve

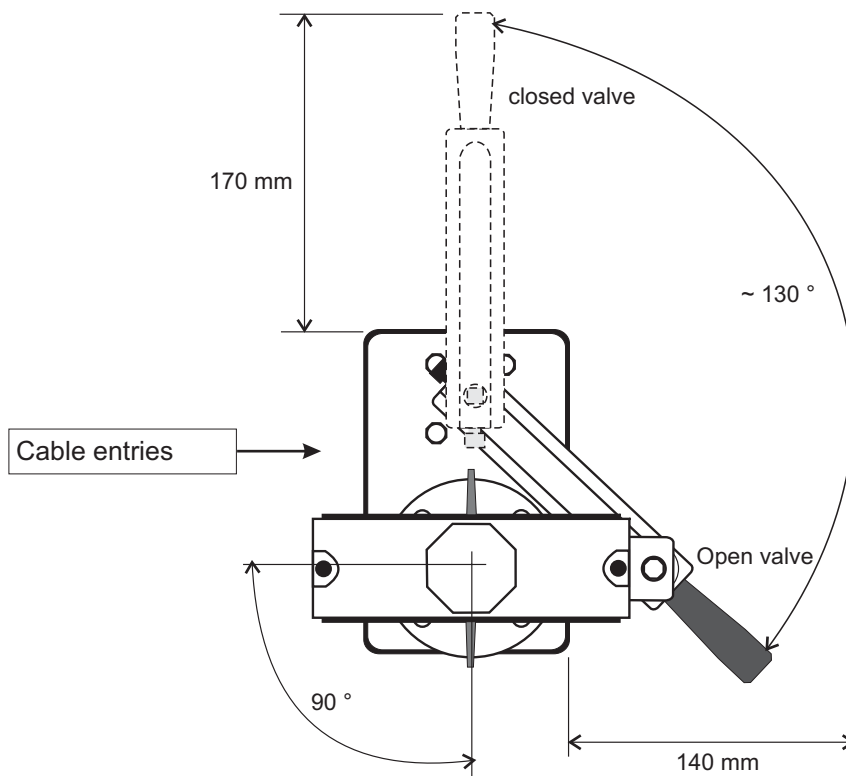

AB Micatrone
Åldermansvägen 3
SE-171 48 SOLNA
SWEDEN

Telephone: +46 8-470 25 00
Fax: +46 8-470 25 99
Internet: www.micatrone.se
E-mail: info@micatrone.se