

MicaFlex Microcontroller-based Differential pressure and flow transmitter with digital indication

MF-FD

version 3.x

mi-277gb / 2008-12-03

Application

MF-FD is a pressure transmitter designed for flow measuring.

At delivery the output signal is set for 0...10 Volt.

Installation

MF-FD is designed for wall mounting. Remove the cover and mount the casing using max $\varnothing 4$ screws in a suitable location. Drill pattern can be found on the backside of the enclosure.

Pressure connections

Connection are made for HT-plastic tube 8/6 mm. Pressure connections [+] and [-] are connected to the flow measuring device according to its guide lines.

Zero adjustment

Switch on the voltage and wait at least 60 sec. Set the manifold valve in position calibration (if there is no valve, loosen the pressure tubes from the MF-FD).

Remove the cover to access the adjustment keys on the main circuit board.

Press down the "zero-setting"-button until the LED turns off. Release the button and the zero-setting is finished.

Output signal setting

The Volt and mA output signal has different terminals. Check that the correct output is connected. Place the miniature switch no 3 in position "OFF" for Volt signal (factory setting) or in position "ON" for mA-signal.

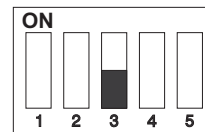

0..10V

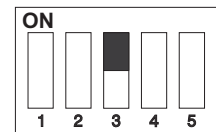

4..20mA

Setting of damping

The MF-FD offers a possibility to set different damping (time constant). At delivery the damping is set to 1,50 seconds damping. Setting is adjusted with the miniature switch contacts no 4 and 5 (the switch is situated on the bottom left edge of the main circuit board, see figure).

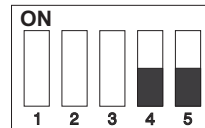

0.05 s

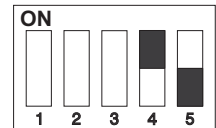

0.70 s

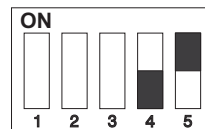

1.50 s

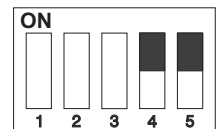

2.20 s

Forced output signal

Depending on the selected output signal, 0...10 volt or 4...20 mA, the max output signal is obtained when miniature switch no 1 is set to position "ON". This function can be used to check the receiving system.



Normal

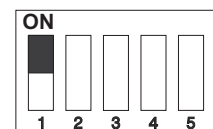

Forced signal
10volt / 20mA

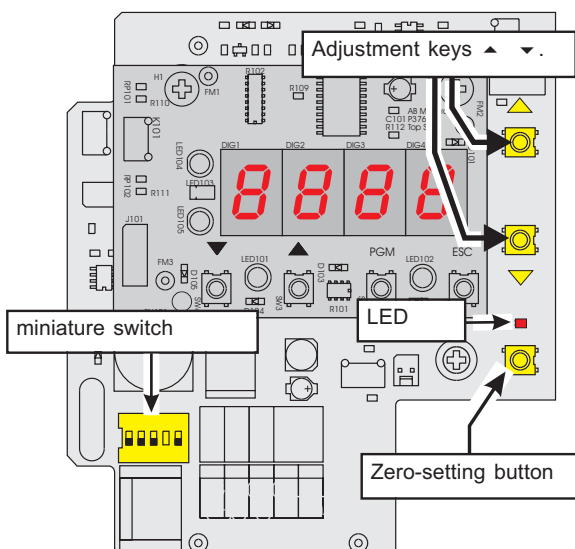

Adjusting the measuring range

The measuring range can be adjusted to correct a measuring deviation. Instruction can be found on our web site, www.micatrone.se.

Display unit

MF-FD is fitted with a 4-digit LED display and two LED's for flow or pressure indication. Shifting between flow or pressure indication is done with the ∇ -key on the display circuit board. This function does not affect the selected output signal, only the indication of measured flow or pressure.

Programming of all parameters is done by four keys on the display circuit board.

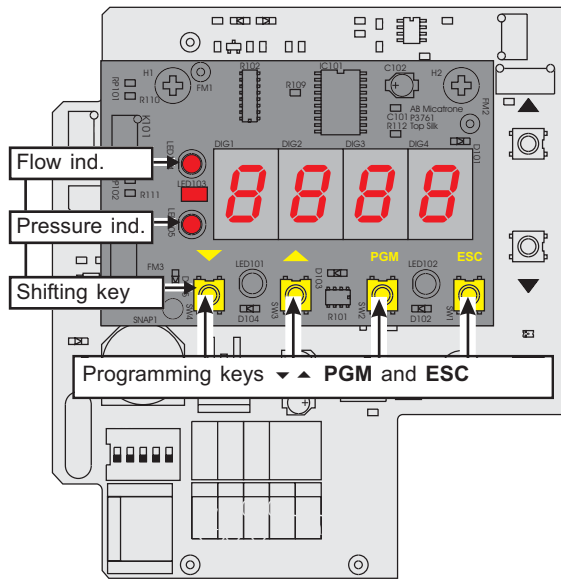

Programming

Micaflex FD is programmable and include following parameters that can be programmed:

Par.no	Description	Range	Preset
P01	Alarm limit	0...9999	0000
P02	Time delay [seconds]	0...600	0000
P03	Low alarm / Off / High alarm	-1 / 0 / 1	0000
P04	Max. value flow in m/s, l/h...	0...9999	0000
P05	Number of decimals for flow indication	0...3	0000
P06	0= Pressure indication/output 1= Flow indication/output	0 / 1	0001

Keep the **PGM** key pressed until P00 is shown. Use the arrow key \blacktriangle to select the parameter to change. Press the **PGM** key to access the selected parameter.

To change the value of the parameter, press the **PGM** key again, the first digit will begin to flash indicating that the digit can be changed. Adjust the value of the digit by pressing the arrow keys \blacktriangle and \blacktriangledown and finally confirm each digit by

pressing the **PGM** key. When the last digit is programmed and confirmed with the **PGM** key, all digits will flash simultaneous and then turn to show the parameter.

Press the **ESC** key to return to normal indication of actual pressure.

Programming flow indication

Calculate the flow for the max. pressure of the transmitter. The max. pressure is noted on the label situated on the right side of the enclosure. Values below 9999 can be displayed. Programming is done in parameter "P04".

Example:

Max pressure gives a flow of 10,50 m³/s.

Program the value 1050 in parameter "P04".

Program the value 0002 in parameter "P05" to obtain two decimals.

Alarm function

MF-FD include a visual alarm indicated by a flashing display on alarm state if this function is activated. By using an optional plug-in module, a potential-free changing relay output can be achieved.

P01, alarm limit 0...9999.

Number of decimals for the alarm limit is selected automatically using the programmed flow indication in parameter "P04".

The alarm is reset automatically when alarm condition no longer exists.

P02, time delay of alarm

This parameter can be programmed to achieve a time delay in seconds before an alarm condition state.

P03, Low alarm, Off, High alarm

This parameter is programmed to obtain alarm at decreasing flow (Low alarm) or for increasing flow (High alarm) or no alarm function (Off).

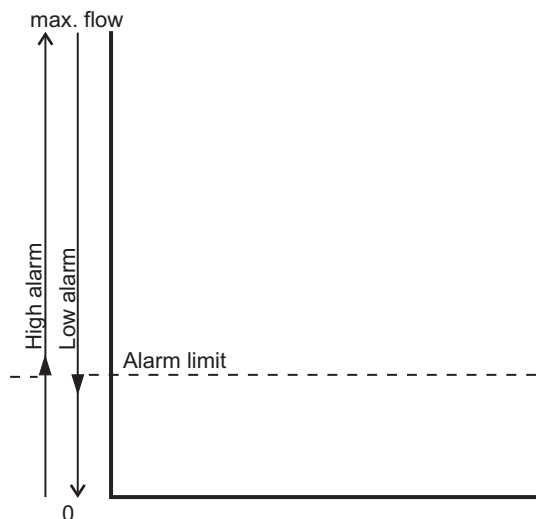

Technical data

Supply voltage: 24 ± 15% VAC, 20...32 VDC
 24, 115, 230 (with transformer), 50/60 Hz

Power cons.: Max. 3 VA (24VAC)
 Max 6 VA (230VAC)

Range: 0...50 Pa
 0...100 Pa
 0...200 Pa
 0...500 Pa
 0...1 kPa
 0...2 kPa
 0...5 kPa
 Other ranges on request.

Max. load: ≤ 50 kPa

Output signal: 4...20 mA max R_L = 400 Ω
 0...10 Volt R_i = 0 Ω

Ambient temp.: 0...55°C

Accuracy: Max error ± 0,5% of the full range plus ± 0,5 Pa.

Temp.drift: Max. 0,5 % per 10°C

Damping: Selectable; 0.05, 0.7, 1.5 or 2.2 s

Degree of protec.: IP 65

El. connections,
 -rigid cable: 1 x 2.5 mm² / terminal
 -flexible cable: 1 x 1.5 mm² / terminal

Cable entries: 2 st threaded holes M16x1,5 (cable glands not attached)

Pressure. conn.: 8/6 mm HT-plastic tube

Dimensions: WxHxD = 122x120x90 mm

Weight: 0,53 kg

Service

MF-FD needs normally no service, but we recommend to check the zero point once a year.

Cleaning

MF-FD should be cleaned with a soft cloth and a light detergent. Do not use scouring powder or dissolvent.

Transformer (Optional)

The output signal is normally NOT galvanically separated to the supply voltage. To obtain galvanic separation between the output signal and the supply voltage on a standard transmitter, the apparatus must be equipped with a plug-in transformer.

Alarm module (Optional)

The MF-FD can be fitted with a built-in alarm module.

The alarm module include a potential-free changing relay output for max. 48 volt / 5 A.

The figure show the relay output in an unpowered state [NC], i.e. alarm state.

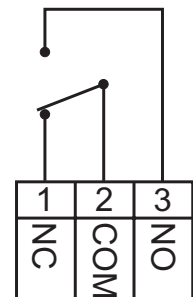

Connection alarm module

(Built-in transformer can not be mounted together with the alarm module)

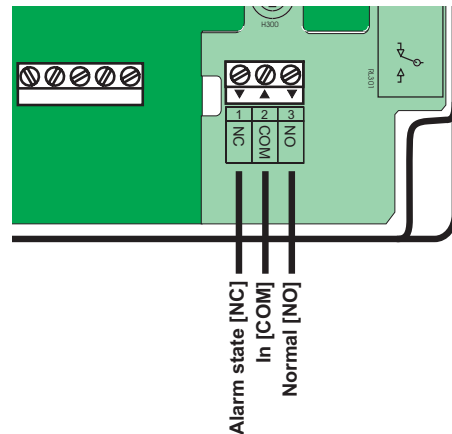

Connection 24 VAC / 20...32 VDC (without transformer)

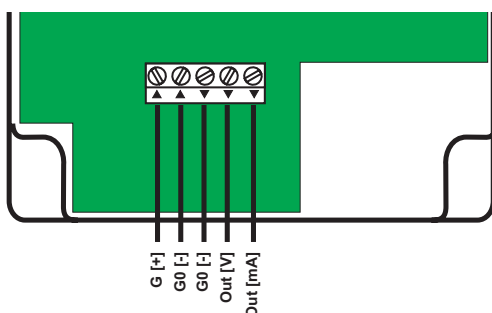

Connection with transformer

(Transformers available for 24/115/230 VAC)

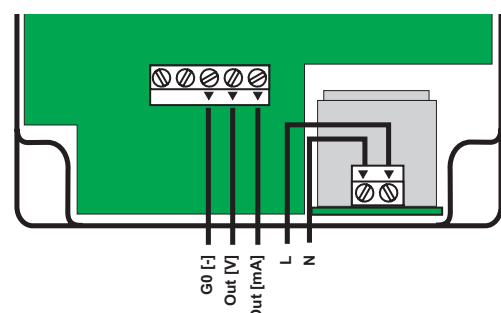

AB Micatrone
Åldermansvägen 3
SE-171 48 SOLNA
SWEDEN

Telephone: +46 8-470 25 00
Fax: +46 8-470 25 99
Internet: www.micatrone.se
E-mail: info@micatrone.se