

### MicaFlex Microcontroller-based Differential pressure transmitter with digital indication

## MF-PD

version 3.x

mi-273gb / 2008-11-21

### Application

MF-PD is a pressure transmitter designed for measuring of low positive, negative and differential pressure.

### Installation

MF-PD is designed for wall mounting. Remove the cover and mount the casing using max  $\varnothing$  4 screws in a suitable location. Drill pattern can be found on the backside of the enclosure.

### Pressure connections

Pressure connections should be made with Micatrone mounting kits for safe and tight function. Connect the measurement outputs with HT-plastic tube 8/6 mm.

- Connect positive pressure to **[+]** connection.
- Connect negative pressure to **[-]** connection.

**NOTE!** Leave unused connections open to the atmosphere.

For differential pressure measurement, ensure that the highest absolute pressure is connected to the **[+]** connection. If the transmitter has a pressure range with zero-crossing (i.e. -50...50 Pa) the high pressure connection **[+]** is connected to the measuring area and the low pressure connection **[-]** is connected to the reference area.

### Zero adjustment

Switch on the voltage and wait at least 60 sec. Set the manifold valve in position calibration (if there is no valve, loosen the pressure tubes from

the MF-PD). Remove the cover to access the adjustment keys on the main circuit board. Press down the "zero-setting"-button until the LED turns off. Release the button and the zero-setting is finished.

### Output signal setting

The Volt and mA output signal has different terminals. Check that the correct output is connected. Place the miniature switch no 3 in position "OFF" for Volt signal (factory setting) or in position "ON" for mA-signal.

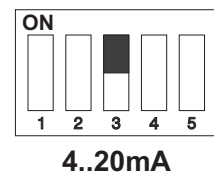
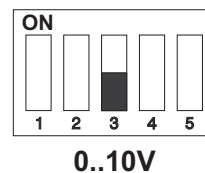

### Setting of damping

The MF-PD offers a possibility to set different damping (time constant). At delivery the damping is set to 1,50 seconds damping. Setting is adjusted with the miniature switch contacts no 4 and 5 (the switch is situated on the bottom left edge of the main circuit board, see figure).

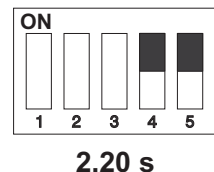
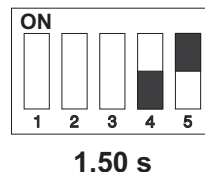
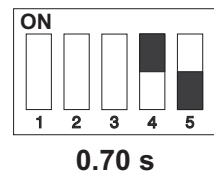
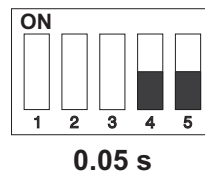

### Half measuring range

Place the miniature switch no 1 in position "OFF" for full measuring range (100%) or in position "ON" for half measuring range (50%).

**NOTE!** The accuracy is always for the full range.

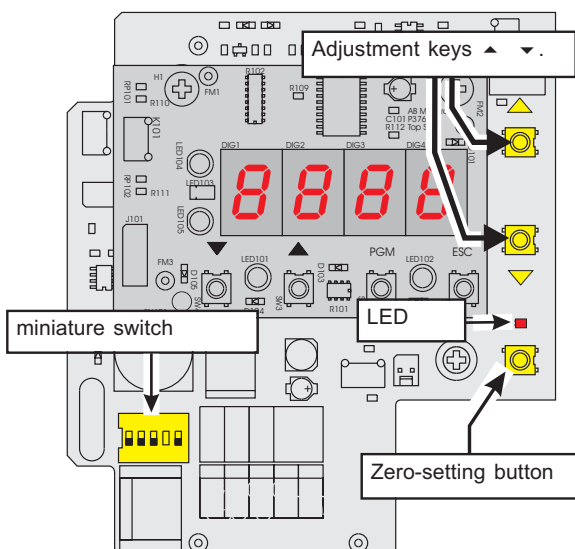
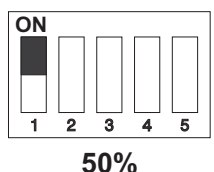
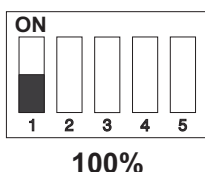

## Adjusting the measuring range

The measuring range can be adjusted to correct a measuring deviation. Instruction can be found on our web site, [www.micatrone.se](http://www.micatrone.se).

## Display unit

MF-PD is fitted with a 4-digit LED display and minus [-] sign when indicating negative pressure.

Programming of all parameters is done by four keys on the display circuit board.

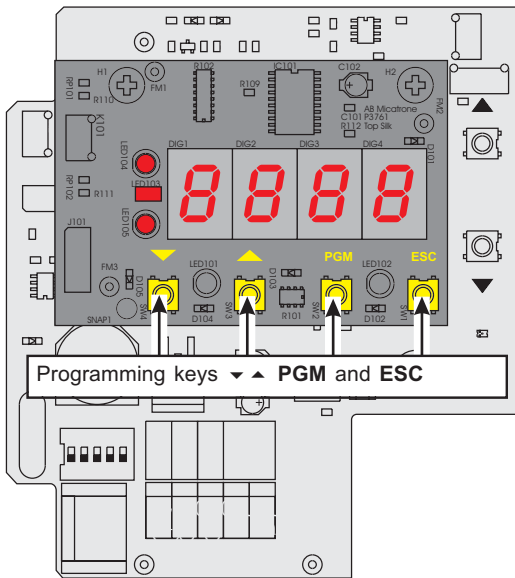

## Programming

Micaflex PD is programmable and include following parameters that can be programmed:

Par.no	Description	Range	Preset
P01	Alarm limit [Pa]	± 0...9999	0
P02	Time delay [seconds]	0...600	0
P03	Low alarm / Off / High alarm	-1 / 0 / 1	0
P04	Negative / Positive -indication	-1 / 0	0

Keep the **PGM** key pressed until P00 is shown. Use the arrow key **▲** to select the parameter to change. Press the **PGM** key to access the selected parameter.

To change the value of the parameter, press the **PGM** key again, the first digit will begin to flash indicating that the digit can be changed. Adjust the value of the digit by pressing the arrow keys **▲** and **▼** and finally confirm each digit by pressing the **PGM** key. When the last digit is programmed and confirmed with the **PGM** key, all digits will flash simultaneous and then turn to show the parameter.

Press the **ESC** key to return to normal indication of actual pressure.

## Alarm function

MF-PD include a visual alarm indicated by a flashing display on alarm state if this function is activated.

By using an optional plug-in module, a potential-free changing relay output can be obtained.

### P01, alarm limit ± 0...9999.

When selecting a negative limit, the alarm limit must be programmed with a minus [-] sign. Low alarm limit is always the lowest pressure compared to the atmospheric pressure.

Example:

ex 1: Positive limit is selected.  
Low alarm limit of 10 Pa, alarm condition occur when the pressure is below 10 Pa (i.e. 9 Pa).

ex 2: Negative limit is selected.  
Low alarm limit of -10 Pa, alarm condition occur when pressure is below -10 Pa (i.e. -11 Pa).

The alarm is reset automatically when alarm condition no longer exists.

### P02, time delay of alarm

This parameter can be programmed to achieve a time delay in seconds before an alarm condition state.

### P03, Low alarm, Off, High alarm

This parameter is programmed to obtain alarm at decreasing pressure (Low alarm) or for increasing pressure (High alarm) or no alarm function (Off).

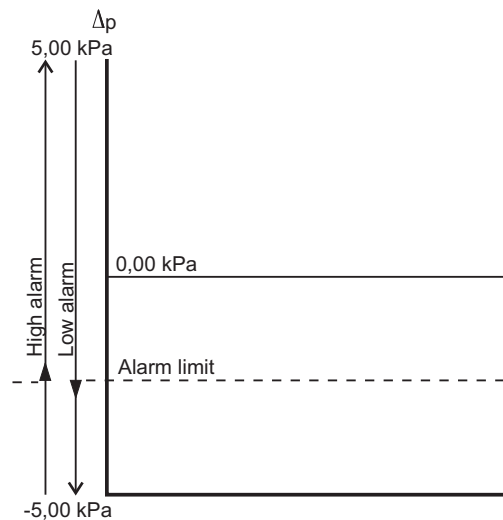

## Negative pressure indication

### P04, Negative / Positive indication

This parameter can be set for either negative, [-], or positive indication of actual pressure

**Technical data**

Supply voltage: 24 ± 15% VAC, 20...32 VDC  
 24, 115, 230 (with transformer), 50/60 Hz

Power cons.: Max. 3 VA (24VAC)  
 Max 6 VA (230VAC)

Range: -50..50 Pa  
 0...50 (0...25\*) Pa  
 0...100 (0...50\*) Pa  
 0...200 (0...100\*) Pa  
 0...500 (0...250\*) Pa  
 0...1 (0...0,5\*) kPa  
 0...2 (0...1,0\*) kPa  
 0...5 (0...2,5\*) kPa  
 Other ranges on request.  
 \*) Half range using a miniature switch. Measuring range with zero-crossing can not be divided.

Max. load: ≤ 50 kPa

Output signal: 4...20 mA max R<sub>L</sub> = 400 Ω  
 0...10 Volt R<sub>i</sub> = 0 Ω

Ambient temp.: 0...55°C

Accuracy: Max error ± 0,5% of the full range plus ± 0,5 Pa.

Temp.drift: Max. 0,5 % per 10°C

Damping: Selectable; 0.05, 0.7, 1.5 or 2.2 s

Degree of protec.: IP 65

El. connections,  
 -rigid cable: 1 x 2.5 mm<sup>2</sup> / terminal  
 -flexible cable: 1 x 1.5 mm<sup>2</sup> / terminal

Cable entries: 2 st threaded holes M16x1,5 (cable glands not attached)

Pressure. conn.: 8/6 mm HT-plastic tube

Dimensions: WxHxD = 122x120x90 mm

Weight: 0,53 kg

**Service**

MF-PD needs normally no service, but we recommend to check the zero point once a year.

**Connection 24 VAC / 20...32 VDC (without transformer)**

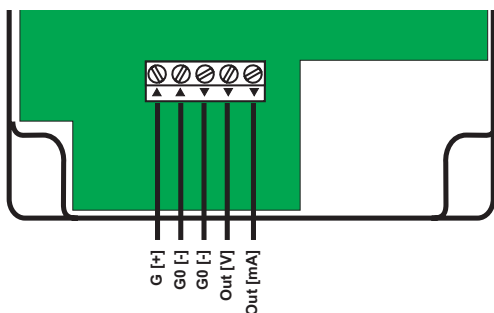

**Cleaning**

MF-PD should be cleaned with a soft cloth and a light detergent. Do not use scouring powder or dissolvent.

**Transformer (Optional)**

The output signal is normally NOT galvanically separated to the supply voltage. To obtain galvanic separation between the output signal and the supply voltage on a standard transmitter, the apparatus must be equipped with a plug-in transformer.

**Alarm module (Optional)**

The MF-PD can be fitted with a built-in alarm module. The alarm module include a potential-free changing relay output for max. 48 volt / 5 A

The figure show the relay output in an unpowered state [NC], i.g. alarm state.

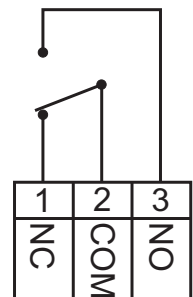

**Connection alarm module (Built-in transformer can not be mounted together with the alarm module)**

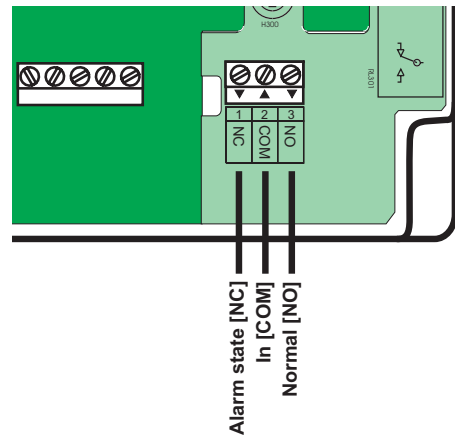

**Connection with transformer (Transformers available for 24/115/230 VAC)**

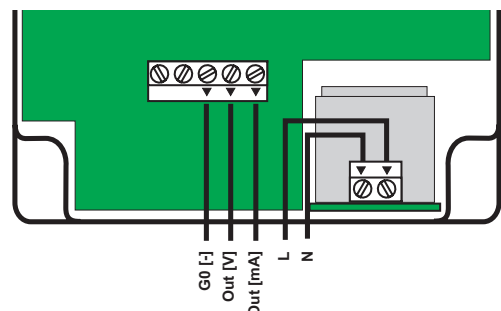

**AB Micatrone**  
**Åldermansvägen 3**  
**SE-171 48 SOLNA**  
**SWEDEN**

**Telephone: +46 8-470 25 00**  
**Fax: +46 8-470 25 99**  
**Internet: [www.micatrone.se](http://www.micatrone.se)**  
**E-mail: [info@micatrone.se](mailto:info@micatrone.se)**