

Differential Pressure Controller with 3-point control output

MRP-2000

Dok.nr: Mi-247gb / 2010-05-25

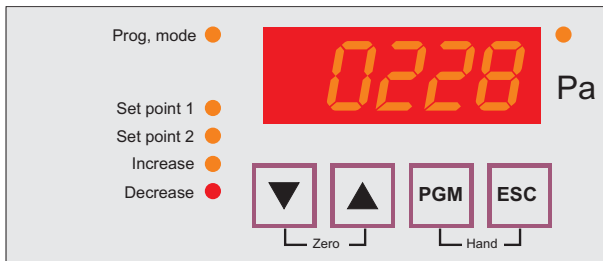

APPLICATION

MRP-2000 is a differential pressure controller with two set points intended for controlling positive, negative or differential pressure on air and gases in combustion plants and air treatment systems. MRP-2000 has a 3-point control output: increase signal, no signal or decrease signal.

FUNCTION

MRP-2000 features special control parameters developed by Micatrone to manage rapid changes without self-oscillation and overshoot.

- Neutral zone around the set point value: the controller is passive (no output signal).
- Pulse zones on each side outside of the neutral zone: the controller gives short pulses.
- Pulse length: time length of the pulse.
- Pulse separation time: time between pulses.

Through pulsing the actuator in the pulse zone (outside the neutral zone) the control sequence slows down to eliminate the risk of self-oscillation around the set point value.

Both the pulse length and the pulse separation time are adjustable to match different operating instances. LEDs indicate which set point value is connected. If there is no phase on terminal 3 then set point value 1 is connected. If there is a phase on terminal 3 then set point value 2 is connected. The LEDs "increase" and "decrease" show the control output signal.

- Outside the pulse zone the controller provides an continuous output signal.

DESIGN

MRP-2000 is designed with three interconnected circuit boards, I/O board, measurement board and the display board. 4-digit indicator with character for negative values and 6 LEDs for status indication. Readable and programmable from the outside.

ABS plastic case equipped with four threaded holes for cable glands. Two pressure outlets for HT-plastic tube 8/6 which can easily be removed for replace-

ment with other couplings with male R1/8" thread. Use a counter hold on the coupling closest to the case when assembling and dismantling the tubes or fittings.

INSTALLATION

MRP-2000 is mounted via 4 screws, max Ø4 mm. The location of the holes is shown back of the enclosure. Do not place the unit on a warm surface. Connect power supply according to the electrical connection. Check that the controller is marked with the correct power supply voltage. If using cable glands without a nut on the inside, glands with grommet must be used to avoid damage to the threads on the enclosure. Remember to remove the transparent protective cover from the front panel after finished installation.

PRESSURE CONNECTION

The pressure connection should be made with Micatrone's pulse line sets to ensure a tight and safe function.

MRP-2000 is available with three different measurement ranges which run through zero: -300...+300 Pa, -3...+3 kPa and -7.5...+7.5 kPa.

The metering socket is connected via the HT-plastic hose 8/6 like this:

1. If MRP-2000 shall control a pressure that is compared to atmospheric pressure, the pressure connection should be made on the + socket (right-hand). This applies whether the pressure is positive or negative compared with the atmosphere. The - socket should remain open.

2. If MRP-2000 shall control a differential pressure, the lowest pressure compared with the atmospheric pressure is connected to the - socket (left-hand). The higher pressure should be connected to the + socket.

DAMPING

Superimposed “noise” frequently occurs when pressure measuring from e.g. burners, fans, etc. It is possible to set different damping (time constant) for the pressure sensor. On delivery MRP-2000 is set to 3.5 seconds attenuation.

1. Open the cover.
2. On the midmost circuit board is a 2-way miniature switch (DIL-switch) in the left-hand lower corner.
3. Set the required damping option in seconds as set out below.
4. Refit the cover.

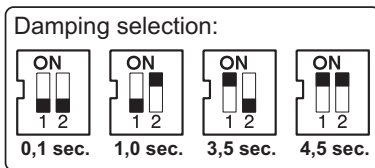

damping of the pressure measurement

PROGRAMMING

Hold down the **PGM** key for 3 seconds and the display will switch from the actual value to the first parameter P00 in the list of parameters. The list of parameters includes eight parameters, the first, P00, can not be changed.

Browse through the list of parameters by pressing the **▲▼** keys and this will display P00, P01, P02, P03, P04, P05, P06 and P07.

Pressing the **PGM** key for the parameter in question shows the set value.

The set value is changed by pressing **PGM** after which the left-hand digit starts to flash. Use the **▲▼** keys to change digit and when the required digit is shown, press the **PGM** key. The next digit to the right will then start to flash and can be changed. Continue along the entire row to the right and press the **PGM** key. The unit responds by flashing the required value three times to acknowledge programming has been successful.

Negative values are entered by pressing the **▼**-key repeatedly when programming the left most digit displayed until the digit turns over from positive to negative numbers. Remaining digits are then programmed as described above until the entire parameter value is entered.

Ongoing programming can be cancelled before the last digit is completed by pressing the **ESC** key.

After programming a value you can return to the list of parameters by pressing the **ESC** key.

Par. no	Description	Range	Factory default
P00	Programme version	X.XX	the current programme version, not re-programmable

P01	Set point 1	-9999..9999 Pa	0 Pa
P02	Set point 2	-9999..9999 Pa	0 Pa
P03	Neutral zone	2..499 Pa	A) 2 Pa B) 20 Pa C) 50 Pa
P04	Pulse zone	1..2499 Pa	A) 10 Pa B) 100 Pa C) 250 Pa
P05	Pulse length	20..3000 ms	500 ms
P06	Pulse separation time	200..3000 ms	1000 ms
P07	Forced operation	0 = decrease, 1 = increase	0 (decrease)

A) Applies to measuring range: -300..+300 Pa

B) Applies to measuring range: -3000..+3000 Pa

C) Applies to measuring range: -7500..+7500 Pa

Note! Do not program setpoints, neutral zone nor pulse zone out of the measuring range!

Set point value

Set point value 1 is programmed in P01 and Set point value 2 in P02. Both set point values have the same neutral zone and pulse zone.

Neutral zone

When the actual value lies in the neutral zone, the controller gives no increase or decrease pulses. The neutral zone is programmed in P03 and lies symmetrical around the active set point value.

Pulse zone

When the actual value lies outside of the neutral zone and in the pulse zone, the controller gives increase or decrease pulses.

The size of the pulse zone is programmed on P04. The pulse length is programmed in P05 and the pulse separation time between pulses in P06. The pulse zones are stated in Pa and lie above and below the neutral zone with equal values (P04).

When the actual value is outside the pulse zone, the controller gives a continuous increase or decrease output signal.

Switching set point values

Switching between set point 1 and 2 is done by connecting power to terminal 3.

No power on terminal 3:

Set point 1 (P01) is activated.

Power on terminal 3:

Set point 2 (P02) is activated

Note ! Power on terminal 3 must be of the same phase as connected on terminal 1.

This method permits, e.g. a stage burner to use different set point values for stage 1 and stage 2.

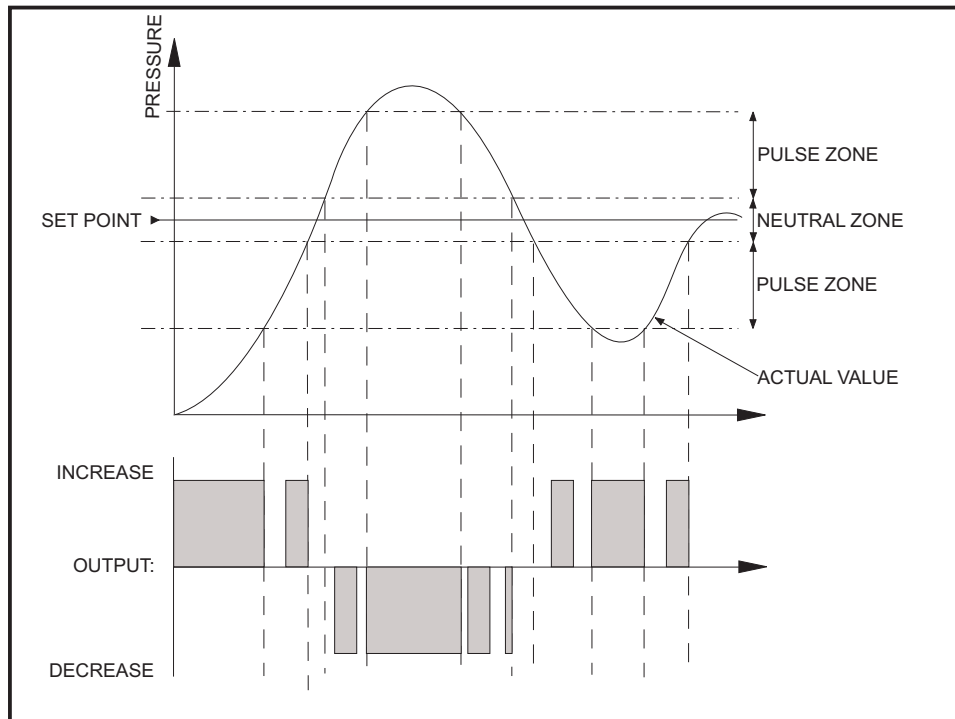

Forced operation

As long as terminals 13 and 14 are connected electrically via an external potential-free contact a continuous increase or decrease signal is given. The forced signal can be set to either increase or decrease in parameter P07.

Manual operation

Activated by pressing the **PGM/ESC** keys simultaneously until the display starts to flash, approximately 3 seconds. The display flashes in manual mode. As long as the **▲** key is held down an increase signal is given and when the **▼** key is held down a decrease signal is given. Manual operation is immediately cancelled by pressing the **ESC** key, or automatically after 30 minutes has elapsed since the last key was activated.

Manual operation takes over the controller's standard function, increase and decrease signals are controlled solely by pressing the **▲** and **▼** keys.

POWER FAILURE

After a power failure the controller returns to regulation of the activated set point value.

CALIBRATION OF THE ZERO POINT

NOTE! Loosen pressure tubes to the unit.

Press down the **▲▼** keys simultaneously and keep these pressed down until the display has gone out, release the keys and the display will show " - - - - " during zero point calibration.

The display shows " 0000 " when zero point calibration is complete.

Calibration of the zero point should be carried out when the unit has reached its normal ambient temperature and been operational for about 60 minutes, and then twice a year.

TECHNICAL DATA

Power voltage:	24 or 230 VAC ±10 % 50/60 Hz See label on side panel of case.
Power consumption:	7.5 VA
Connecting set point 2:	24 or 230 VAC (Same phase as term. 1)
Ambient temperature:	0...55 °C
Measuring range:	See label on side panel of case. (-300...+300 Pa) (-3000...+3000 Pa) (-7500...+7500 Pa)
Measurement error:	≤ ± 1 % FS
Max pressure load:	25 kPa
Output Relays:	2 pcs.
Max load on relays:	24/230 VAC, 2 A cos φ = 1
Electrical terminals:	
- Supply voltage:	Max. 2x1,5 mm ² wire
- Relays:	Max. 2x1,5 mm ² wire
- Forced operation:	Max. 2x0.75 mm ² wire
Cable entries:	2 pcs M16 + 2 pcs M20
Degree of protection:	IP 65
Pressure connections:	8/6 HT plastic tube
Dimensions [HxWxD]:	120x200x57 mm (pressure conn. not accounted for)
Weight:	0,75 kg

ELECTRICAL CONNECTION

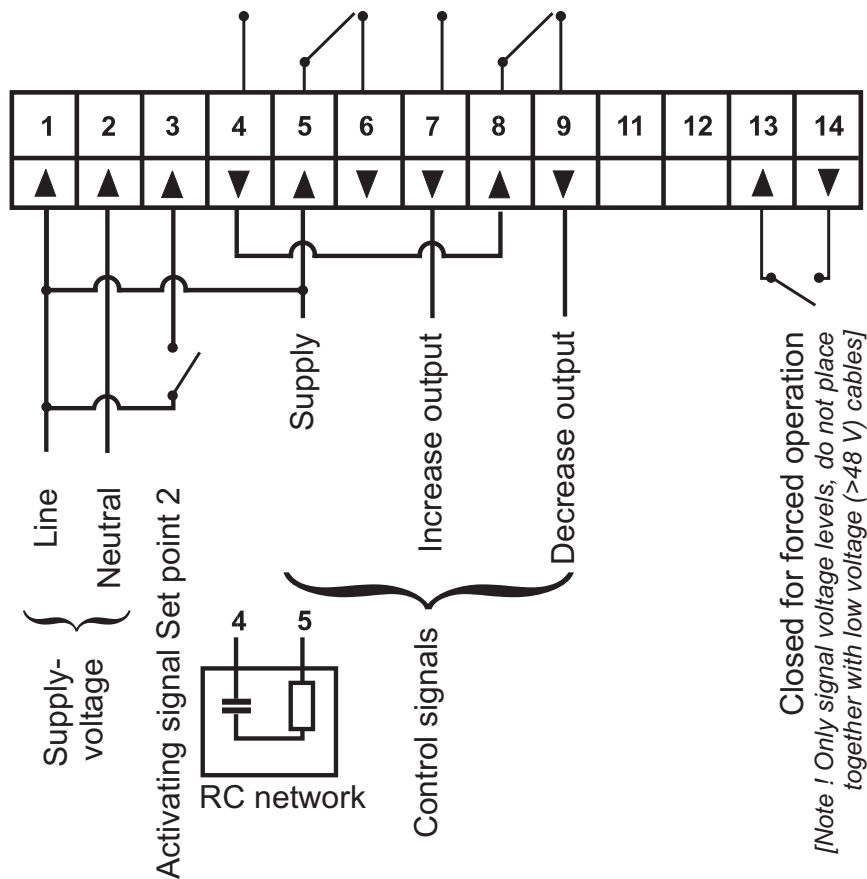

Compliance

-EMC: SS-EN 50081-1
SS-EN 50082-2
-LVD: SS-EN 61010-1

Maintenance

Calibration of the zero-point twice a year is recommended.

Power voltage

MRP-2000 is voltage fed with 24 or 230 VAC according to the rating plate on the end of unit. The Phase is connected to terminal 1 and Neutral to terminal 2.

Control signals

If the control signals are to have the same voltage supply as MRP-2000, terminals 1 and 5 are strapped.

If the control signals are to have a different voltage, remove the strap between 1 and 5 and connect another supply to terminal 5.

The relay contacts behind terminals 4, 5, 6 and 7, 8, 9 are potential-free.

RC-network

The supplied RC network is used to reduce electrical interference (EMI) when the increase and decrease pulses are given and should be installed between terminals 4 and 5. The RC-network also prolongs the life of the relay for the control signal.

Unexpected behaviour can be experienced if the control signal from MRP-2000 is connected to intermediate relays or very small actuators. External relays or actuators can react to the small leakage current that passes through the RC-network and give incorrect increase or decrease signals. This also applies when the actual value is inside the neutral zone. Should this behaviour occur disconnect the RC-network.

AB Micatrone
Åldermansvägen 3
SE-171 48 SOLNA
SWEDEN

Telephone: +46 8-470 25 00
Fax: +46 8-470 25 99
Internet: www.micatrone.se
E-mail: info@micatrone.se