

MicaFlex system for fume hood constant average face velocity control :
MF-FHM / MF-FHC / HSA-24SR2

Fume Hood Control

md-1295gb / 2009-02-05

Application

The MicaFlex system for fume hood face velocity control is developed for continuous measuring, control and monitoring of the face velocity of the fume hood sash opening and by that, guarantee the safety of the operator and laboratory personnel.

The system also offers the lowest possible energy cost when the inflow is kept at lowest possible value of 0,5 m/s irrespective of the level of the fume hood sash opening.

The MicaFlex fume hood system consists of;

- ✓ **Operator monitor, FHM**
- ✓ **Control unit, FHC, with built in sensor**
- ✓ **Actuator, HSA-24SR2**
- ✓ **Damper**

Design

The operator monitor, FHM, is mounted on the front of the fume hood. The control unit, FHC, with built in flow sensor is mounted on top of the fume hood and connected to a measure connection inside the fume hood.

The damper control is performed very rapidly and accurately by the actuator, HSA-24SR2.

The system also consists of special dampers with very low friction. These are available as zincified, epoxy painted or stainless steel.



Operator monitor FHM

Operator monitor FHM



The FHM has a two-line display with a total of 32 signs. During operation, the actual face velocity is indicated in m/s together with selected function: *Normal flow*, *High flow*, *Low flow* and at alarm, *Alarm high/Alarm low*.

Three LED's indicates alarm status: *Normal*, *Caution* and *Alarm*.

The mode of operation is selected by the keypad:

1. Normal flow
2. High Flow (forced flow)
3. Low flow (minimized flow used for setting etc)
4. Test/Reset: test of alarm and reset of alarm.

At fault condition, an alarm signal sounds and a voltage free relay contact changes. To minimize the number of keys, they are also used for programming. By pushing the Low Flow key for 20 seconds, the keys functions are changed and all registers are opened for programming. The operator monitor is connected to the control unit MicaFlex FHC via a stationary shielded cable.

Control unit FHC



The control unit, which is based on a micro processor, has two analogue outputs (volt/mA), one for velocity and one for control of the damper actuator.

The alarm function has two voltage free relays which can be programmed for high or low flow for each mode of operation and with programmable time delay. The alarm function can also be used for electric interlock for example of heating in the fume hood so that the heating is stopped at a low velocity. If the flow is too low, a buzzer will sound after set time delay. After a set time delay, the relay operates and the heating will be stopped. Resetting of the alarm before the relay responds prevents the electric interlock. The velocity can be set from a distance to be high or low.

Sensor

The control unit, FHC, has a built in sensor. The sensor is used for measuring the velocity of the fume hood sash opening.

The sensor consists of a bi-directional mass flow sensor with very small pressure range, 0...4 Pa, corresponding to $\approx 0...2,0$ m/s. The pressure difference is measured between the fume hood and the laboratory.

The time constant for the sensor is ≤ 3 msec. The sensor has an excellent long time stability.

The connection of the sensor to the fume hood is made through a self-averaging pressure connection. Zero setting and calibration is made via the operator monitor.

High speed damper actuator HSA-24 SR2



The actuator is a high speed damper actuator with 1,5 sec between open and closed position.

The electric motor is a 24 VAC synchronous motor that guarantee a long life. The control input signal is 0...10 VDC and a output position signal 0...10 VDC is also available. A bar-graph indicate the position 0...100 %. The actuator has an output shaft with an internal hole for a 10x10 mm damper shaft.

The actuator is suitable for low friction dampers up to 500 mm.

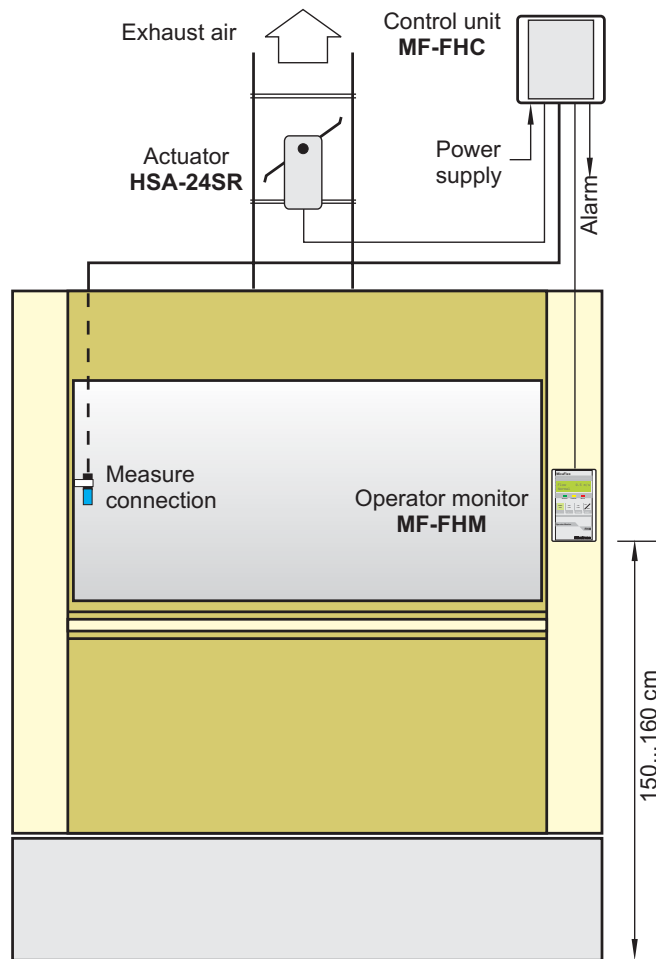

Function

The sensor measures the pressure difference between the fume hood and the laboratory. The output signal is linearized to a flow linear signal for 0...2,0 m/s. The control unit processes the signal and sends a control output signal to the actuator. During operation the actual face velocity is indicated on the monitor display together with the selected mode of operation. Green LED indicates normal flow. Yellow LED warns for deviation and red LED indicates alarm after a set time delay. The monitor also includes a buzzer which is activated together with the red LED. Reset of alarm is done with the reset-key. The reset can be programmed to be effective after a set time or until the velocity is correct.

The operator selects the mode of operation via the keypad; *Normal* for normal flow, *High* for forced flow and *Low* for low flow, which is used during setting or unused fume hood. These functions may also be set from a distance by closing of the contacts. The Test/Reset-key is used for function test and re-setting of alarm. When closing the plant, the alarm function may be blocked from a distance through a voltage free contact. The control is performed very rapidly. A change of the fume hood sash opening requires only about one second until the hood face velocity is correct. The programming is performed through a simple menu system. Each mode of operation has a separate set of values for velocity and alarm limits for high or low velocity.

Special design

The MicaFlex system can be designed to suit fume hoods with automatic fume hood sash control. A complete description of the fume hood sash automatic function will be required when ordering.

Technical data

Operator monitor FHM:

Display: 2 rows, 32 signs
LED: Green, yellow, and red
Keypad: 4 keys for change of mode; Normal, forced, low velocity and test/reset of alarm. Programme mode protected by time delay.
Connection: Connection to control unit by a shielded 2 meter cable with plug-in contact.
Buzzer: 85 dB (10 cm)
IP class: IP-54
Dim: 160x80x37 mm

Control unit FHC:

Outputs Two analogue 0/2...10 VDC/0/4...20 mA for control and velocity actual value
Inputs. Two digital for forced and low flow. One digital for remote reset of alarm.
Alarm: Two switching relay contacts max 48 VAC-5 A/48 VDC-1,5 A
Power supply: 24 VAC± 15% /20...32 VDC
Power consumption: 4 VA
IP class: IP-65
EI-connection: Max 1x1,5 mm² per terminal
Cable entry: 4 pcs M16 x 1,5
Dim: 120x122x90 mm

Built in sensor:

Type: Mass flow sensor
Measure range: 0...4 Pa (0...2,0 m/s)
Measurement error: <± 0,05 m/s after flowlinearization

Electric connection control unit FHC:

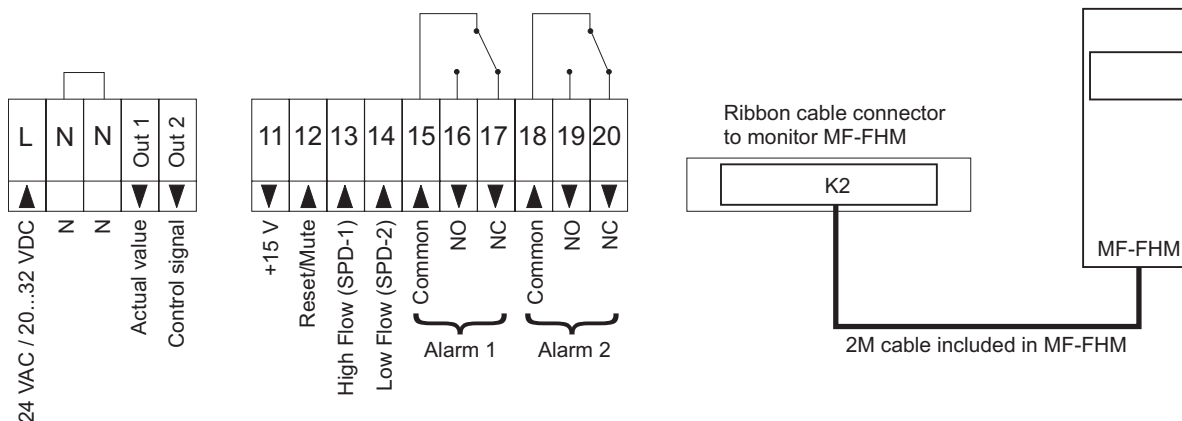

Actuator HSA-24SR2:

Control signal: 0...10 VDC
Position outputsignal: 0...10 VDC
Running time: 90° 1,5 sec
Power supply: 24VAC
Power consumption: 34 VA, 17 W
Torque: Min 2,5 Nm
Rotation angle: Adjustable
IP class: IP-54
EI-connection: 4-wire cable 1 m fixed connected
Connection: Direct connection to 10 mm squared shaft
Dim: 80x140x155 mm

System accessories:

- Transformer
- Attendance sensor
- Damper, coated with zinc, stainless steel or epoxy painted
- Transmitters and controllers for constant pressure control, balancing of supply and exhaust air, zone control and temperature control.

Electric connection actuator HSA-24SR2:



AB Micatrone
 Åldermansvägen 3
 SE-171 48 SOLNA
 SWEDEN

Telephone: +46 8-470 25 00
Fax: +46 8-470 25 99
Internet: www.micatrone.se
E-mail: info@micatrone.se